

PXI Dual channel 24-bit / 192ksps AWG

PG24192

- Two channels, fully differential outputs
- Excellent dynamic performance
- 125dB THD at 1kHz with 1.2kHz filter
- Programmable common mode level
- 10mVpp to 10Vpp output range
- Low impedance or 600- Ω output impedance
- Internal clock supports all standard audio rates
- Local bus clock for sync. to PD24222



The PG24192 is a PXI, Dual Channel Arbitrary Waveform Generator. It features fully differential outputs and a very low distortion. A programmable common mode voltage allows adapting to circuits that need a DC offset at their inputs. For single ended applications the positive output as well as the negative output can be used.

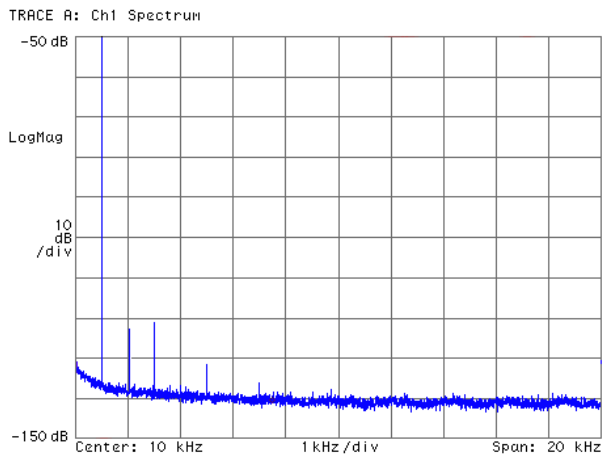

DC to 20kHz spectrum, 1KHz carrier, 96ksps, 22kHz filter (levels are dBc, carrier above 50dB not shown).

The unit is very suitable for audio type of measurements. The ranging is continuous from 10mVpp to 10Vpp with a resolution of <0.1dB. The two channels are ideal for stereo and crosstalk measurements. There is a 1.2kHz low pass filter that reduces the harmonics for 1kHz signals to even lower levels. For most measurements the 22kHz filter is an excellent choice. If wide band operation is required the 100kHz filter can be selected.

The internal clock sources can generate all standard audio sample rates and more. The External clock and trigger capability give the user full control of the measurement timing. If the PD24222 is used as digitizer, the clocks of the two units can be synchronized via the local bus capability of the PXI backplane. This allows coherent clocking for best measurement results.

PXI Dual channel 24-bit / 192ksps AWG

Block diagram

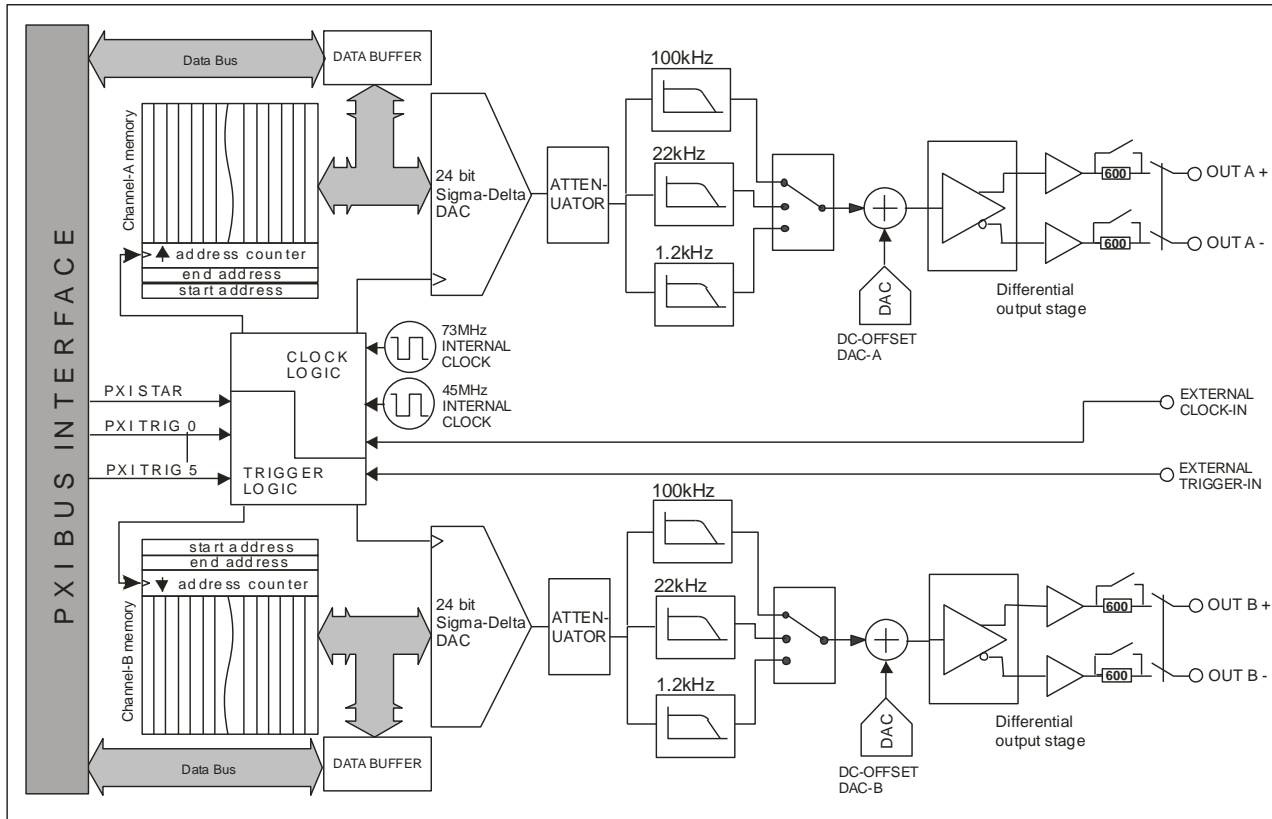

Specifications (conditions: $T_A=25^\circ\text{C}$)

General

Channels	2
Resolution	24-bit
Update rate, internal clock	3.675ksps - 192ksps
Update rate, external clock	1ksps - 220ksps
Memory depth	1M-word per channel
Output range	10mV to 10Vpp continuous
Output configuration	Single ended or differential
Output impedance	600- Ω or low impedance
Analog filters (low pass)	100kHz, 22kHz or 1.2kHz
Output operating area	-10V to +10V

Accuracy

Amplitude accuracy	$\pm 0.05\text{dB}$ @ 1kHz/10Vpp
Frequency flatness	0.2dB from 20Hz to 20kHz

Dynamic characteristics

(Vout = 10Vpp, f-upd.=192ksps)	
SINAD (1kHz)	107dB (BW=20kHz)
SFDR (1kHz)	112dB
THD (1kHz)	110dB
THD (1kHz with 1.2kHz filter)	125dB (typical)
THD (10kHz)	103dB

Common mode voltage source

Voltage range	-5V to +5V.
Resolution	16-bit (152 μV)

Clock & Trigger inputs

Clock Input	50- Ω , $V_{IL}<0.6\text{V}$, $V_{IH}>1.4\text{V}$
Trigger input	10k Ω , $V_{IL}<0.8\text{V}$, $V_{IH}>2.0\text{V}$

Triggering

Trigger sources	Software, External, PXI STAR, PXI TRIG 0..7
Trigger capabilities	edge or level, positive or negative going. Independent trigger source selection per channel